



CB 1565 HC

Ice Cube



Self-contained ice maker - Sprayer system Daily production up to 160 kg

Hotel	████████████████████
Restaurant	██████████████████
Fast food	██████████████████
Bar	██████████████████
Disco	██████████████████
Fish market	██████████████████
Supermarket	██████████████████
Medical & SPA	██████████████████
Industry	██████████████████

► Position n°



► Features & Plus

- Compact and crystal cube
- AISI 304 SS Scotch Brite finish
- Tropical class +43°C
- Adjustable Stainless Steel feet
- Air or water cooling system
- Easy cleanable internal rounded surfaces
- HCFC-Free insulated storage
- RoHS Free
- Disappearing insulated door
- Electromechanical operation
- ON-OFF rocker switch
- Standard and special voltages
- HFC Free



AISI 304 SS Scotch Brite finish



Adjustable Stainless Steel feet



Easy cleanable internal rounded surfaces



Disappearing insulated door

► Available ice cube size

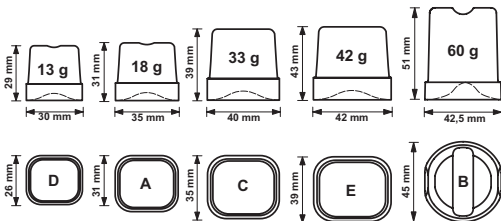

► Prod. 24h

Air temp.		Water temp.		kg	lbs
10° C	50° F	7° C	45° F	160	353
21° C	70° F	15° C	60° F	152	335

2 Years Warranty
subject to limitations

► Certifications available for this model



www.bremagroup.it
info@bremaicegroup.it

We are Brema





Ice Cube

CB 1565 HC



Self-contained ice maker - Sprayer system Daily production up to 160 kg

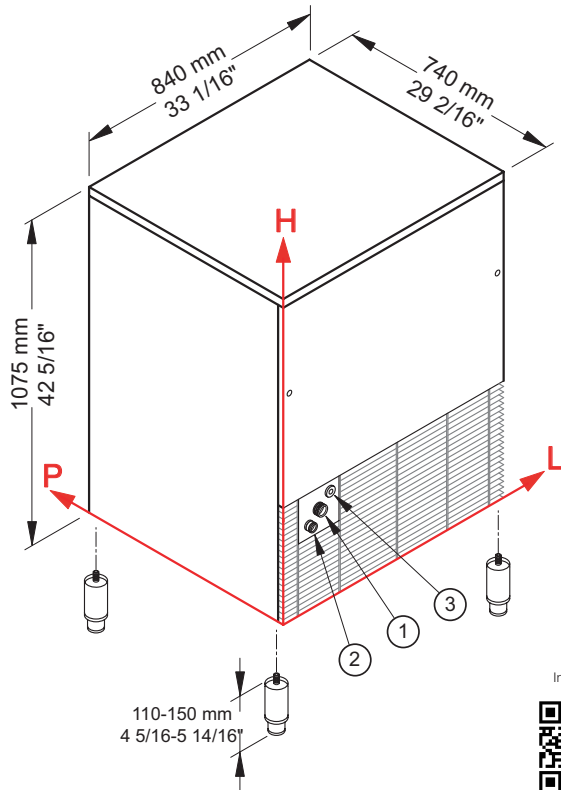

Installation



► Working conditions

- Location: Indoor

	Min	Max
Ambient temperature	+10° C / +50° F	+43° C / 110° F
Water temperature	+3° C / +37° F	+32° C / +90° F
Voltage	-10%	+10%
Water inlet pressure	1bar (14 psi)	6bar (84 psi)

► Performances

		Water temperature					
		7° C	45° F	15° C	60° F	21° C	70° F
Air temperature	10° C	160 kg					
	50° F		353 lbs				
	21° C			152 kg			
	70° F				335 lbs		
	32° C					145 kg	
	90° F						320 lbs

► Connections

All measures are referred to the rear bottom-left corner (L-H-Ø)

- ① Water in.: 141 mm / 5 9/16" - 290 mm / 11 7/16" - 3/4"
- ② Water out.: 79 mm / 3 2/16" - 245 mm / 9 10/16" - 24 mm / 15/16"
- ③ Electrical connections: 186 mm / 7 5/16" - 326 mm / 12 13/16"

► Technical information

Production in 24h	160 kg / 353 lbs
Store capacity, up to	65 kg / 143 lbs
Cooling system	A - W
Kind of cube	A-18g, C-33g, D-13g, E-42g, B-60g
Refrigerant	R290
Standard voltage	220-240 V ~ 50 Hz
Average power consumption	1280 W
Fuse	16 A
Electrical consumption	20 kWh/100kg

Water consumption	A: 2 l/kg - 24 gal/100 lbs
	W: 11,9 l/kg - 142,6 gal/100 lbs
Sizes (L-P-H mm)	840 - 740 - 1075
(L-P-H in)	33 1/16 - 29 2/16 - 42 5/16
Sizes with pack (L-P-H mm)	880 - 785 - 1245
(L-P-H in)	34 10/16 - 30 14/16 - 49
Net weight	118 kg / 260 lbs
Gross weight	138 kg / 304 lbs
Finish	AISI 304 stainless steel, scotch brite

All the technical information must be considered at the following conditions:

- Sizes without feet
- Standard Cube (18 g)
- Ambient temperature +21° C
- Water temperature +15° C
- Electrical consumption at +32° C (standard voltage)
- Average power consumption at +43° C (standard voltage)

Models and specifications are subject to change without notice

Rev. 04 - Issued March 2025



www.bremagroup.it
info@bremaicegroup.it

We are Brema

